

# H-1X & UC65e Drain Water Tempering Valve Kit

## PN 13470.55

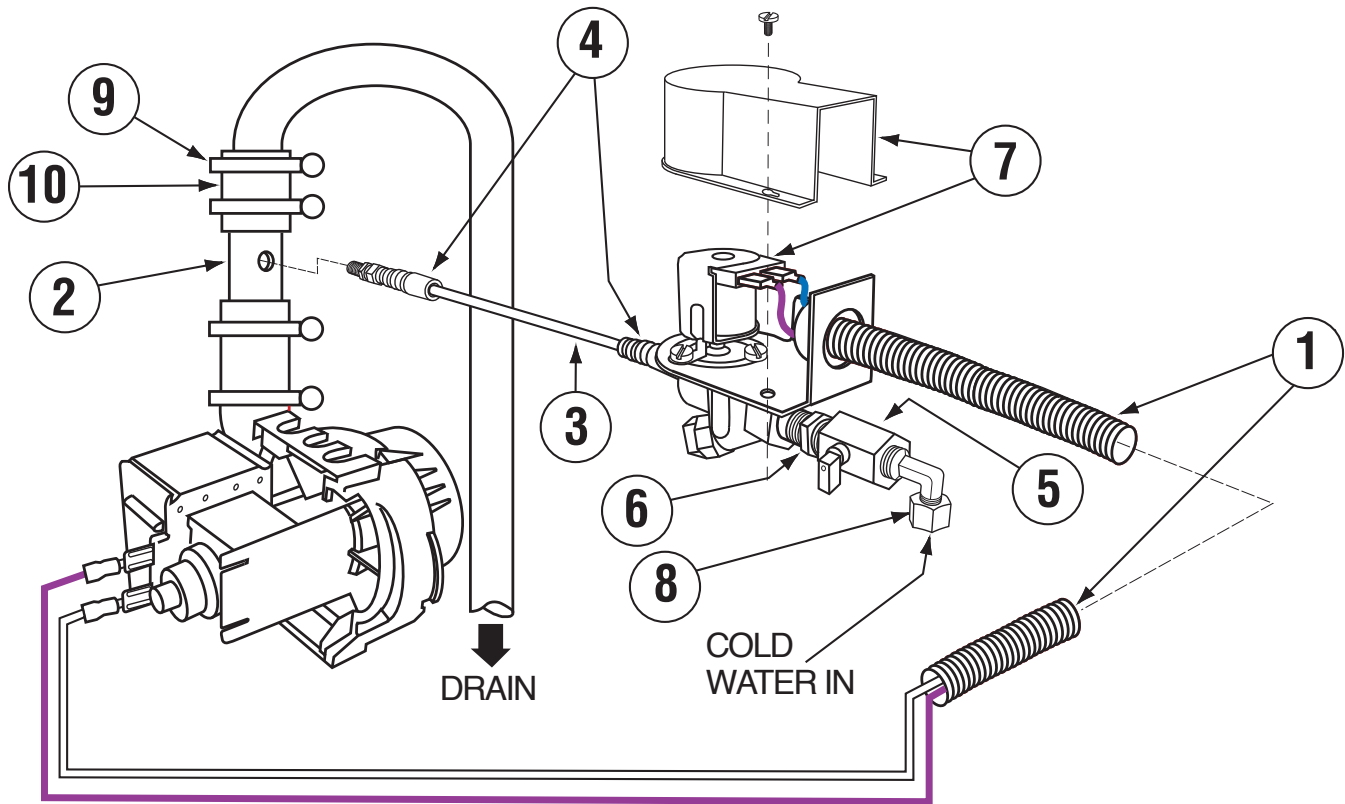

### INSTALLATION INSTRUCTIONS TO DRAIN TEMPERING KIT

NOTE: Turn the dishwasher's wall breaker to "OFF" position before this installation.

1. Undo the drain hose clamp connecting drain hose leading to floor drain
2. Install the water junction tee, as shown on drain line, and tighten clamp
3. Connect the drain hose to upper port of water injection tee and tighten hose clamp
4. Insert the provided white chemical tube into compression nut of water injection tee and tighten compression nut
5. Connect the provided cold-water solenoid's power leads to the drain solenoid
6. Connect the water injection assembly's ball valve to a cold water supply.
7. Run the dishwasher through a few cycles and make sure the cold water is injected and check for any possible leaks.

| ITEM NO. | NO. REQ'D | P/N      | DESCRIPTION                 |
|----------|-----------|----------|-----------------------------|
| 1        | 2.5       | 15400.17 | 3/8" Slit ribbed Tubing     |
| 2        | 1         | 15603.50 | Goose Neck Pipe Adapter Tee |
| 3        | 2         | 00425.54 | Chemical Tubing White       |
| 4        | 2         | 03415.50 | Flex-tight Fitting          |
| 5        | 1         | 41014.49 | 3/8" Ball Valve             |
| 6        | 2         | 40015.00 | 3/8" X 1/4" Hex Bushing     |
| 7        | 1         | 41015.00 | Solenoid Valve 1/4" 115V    |
| 8        | 1         | 40112.00 | 1/4" Comp X 1/4" MIP Elbow  |
| 9        | 2         | 03101.00 | Hose Clamp #16 1"           |
| 10       | 0.25      | 03108.60 | Transfer Hose 1" Reinforced |