



# WIRE DIAGRAM FOR MODEL: EST-66

Rev. 1.01

w/TRANSFORMER: 480/575/600, DUAL FLOATS.

11/19/2014

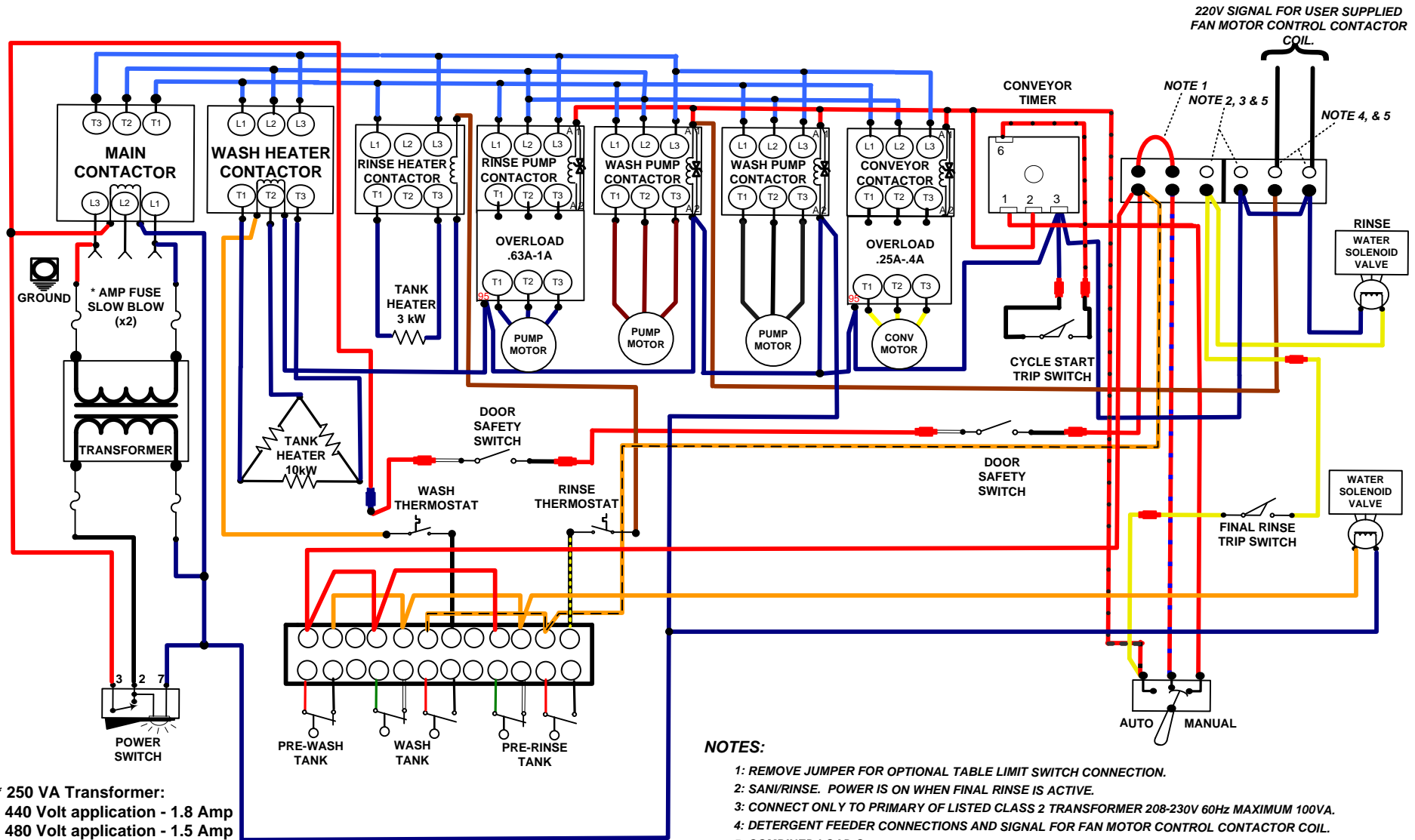

\* 250 VA Transformer:  
440 Volt application - 1.8 Amp  
480 Volt application - 1.5 Amp  
\* 350 VA Transformer - 1.8 Amp

### NOTES:

- 1: REMOVE JUMPER FOR OPTIONAL TABLE LIMIT SWITCH CONNECTION.
- 2: SANI/RINSE. POWER IS ON WHEN FINAL RINSE IS ACTIVE.
- 3: CONNECT ONLY TO PRIMARY OF LISTED CLASS 2 TRANSFORMER 208-230V 60Hz MAXIMUM 100VA.
- 4: DETERGENT FEEDER CONNECTIONS AND SIGNAL FOR FAN MOTOR CONTROL CONTACTOR COIL.
- 5: COMBINED LOAD OF USER DEVICES (CHEMICAL PUMPS, FAN CONTROLS, ETC.) MUST NOT EXCEED 1.5 AMPS.