

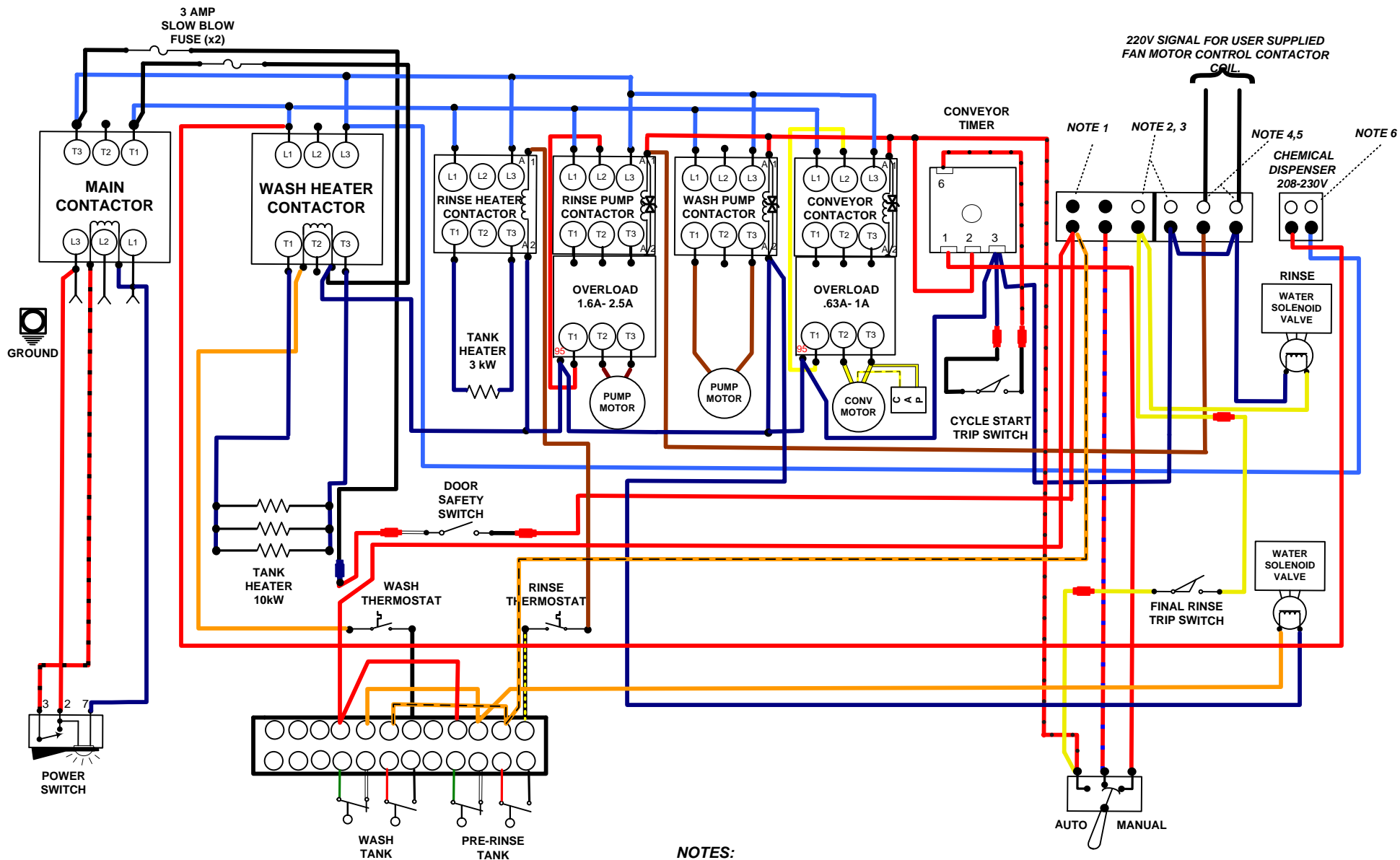

WIRE DIAGRAM FOR MODEL: EST-44 (230 VAC single-phase, dual floats)

Rev. 2.04

11/19/2014



NOTES:

- 1: TABLE LIMIT SWITCH CONNECTION PRE-WIRED AT FACTORY.
- 2: SANI/RINSE. SIGNAL IS ON WHEN FINAL RINSE IS ACTIVE.
- 3: CONNECT ONLY TO PRIMARY OF LISTED CLASS 2 TRANSFORMER 208-230V 60Hz MAXIMUM 100VA.
- 4: DETERGENT FEEDER SIGNAL AND FAN MOTOR CONTROL CONTACTOR COIL.
- 5: COMBINED LOAD OF USER DEVICES (CHEMICAL PUMPS, FAN CONTROLS, ETC.) MUST NOT EXCEED 1 AMP.
- 6: DISPENSER POWER BLOCK 208-240 VOLTS