

e-Temp Quick Setup Instructions

WARNING Electrical and plumbing connections need to be made by a licensed service person and comply with all Federal, State and Local Health, Electrical, Plumbing and Safety codes.

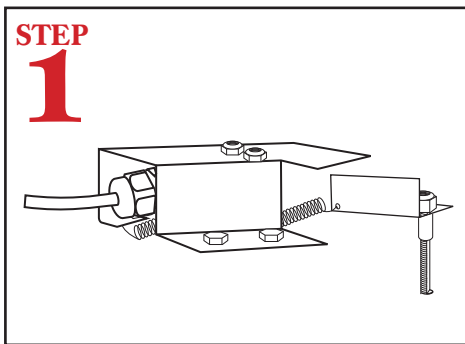

Turn on dishmachine by pressing the "POWER ON/OFF" switch to the "ON" position. Switch Manual/Auto switch to Manual Mode. Press rinse switch to fill E-Temp tank. When water appears from the final rinse arms, this indicates E-Temp tank is full.

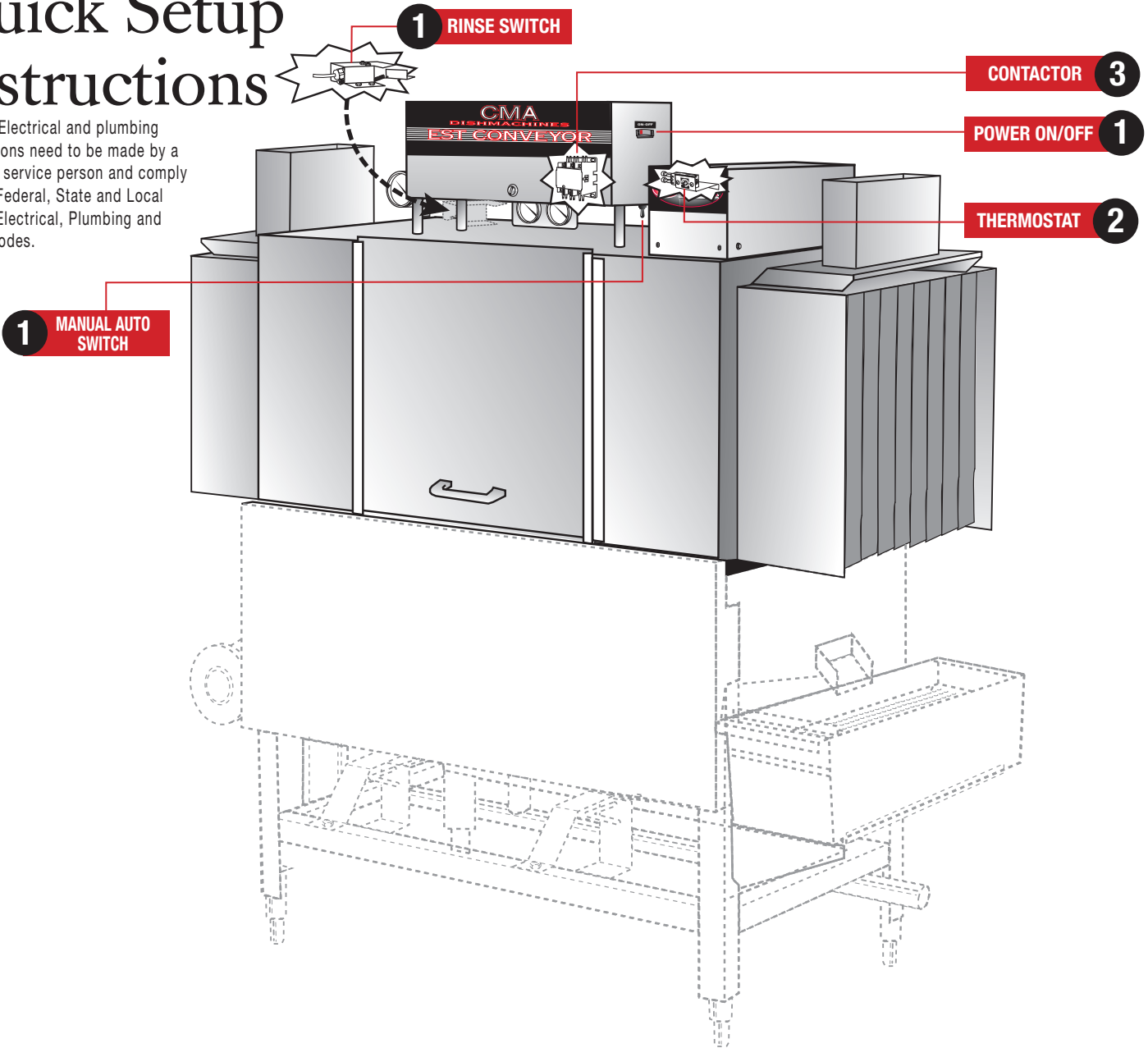
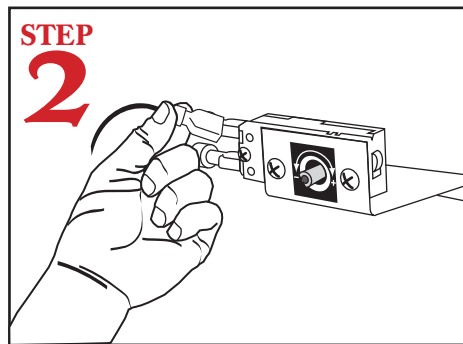

When the E-Temp tank is full, reconnect thermostat wire.
NOTE: thermostat wire was removed at factory to prevent damage to heating element.

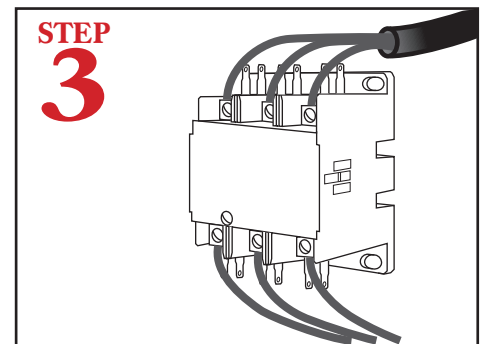

The E-Temp contactor is located inside the control box and will require a separate power connection.

AMP Draw for 40°rise	AMP Draw for 70°rise
208 V, 25 AMP	208 V, 42 AMP
240 V, 29 AMP	240 V, 48 AMP
480 V, 15 AMP	480 V, 22 AMP