

# SERVICE BULLETIN

**Date:** MARCH 1, 2011  
**Log Number:** 123  
**Models Affected:** EST-44/ EST-66  
**Subject:** EST-44/66 POWER CONNECTION

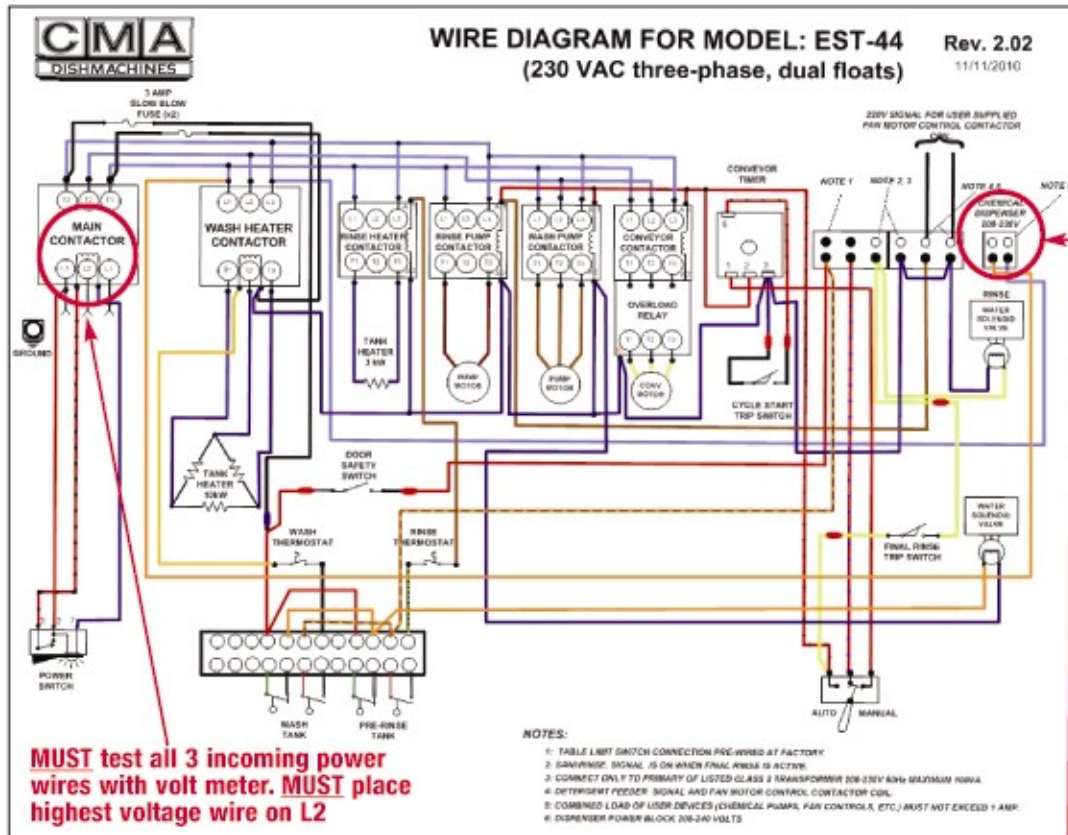

**MUST test all 3 incoming power wires with volt meter. MUST place highest voltage wire on L2**

## WARNING

To prevent excessive overloads and component damage, it is essential for dispenser power supply to be wired to supplied power block on all EST-44 and EST-66 Conveyors. The CMA supplied power block, for your dispenser, has been prewired to the wash heater contactor L1 and L3 terminals, to assure correct and balanced power to the dispenser and surrounding components. It is most important that, if the 3-phase power supply from the facility has a Hi-Leg (wild leg), it must be connected to L2 to prevent overloading the contactor coils.

**DISPENSER POWER BLOCK 208-240V**

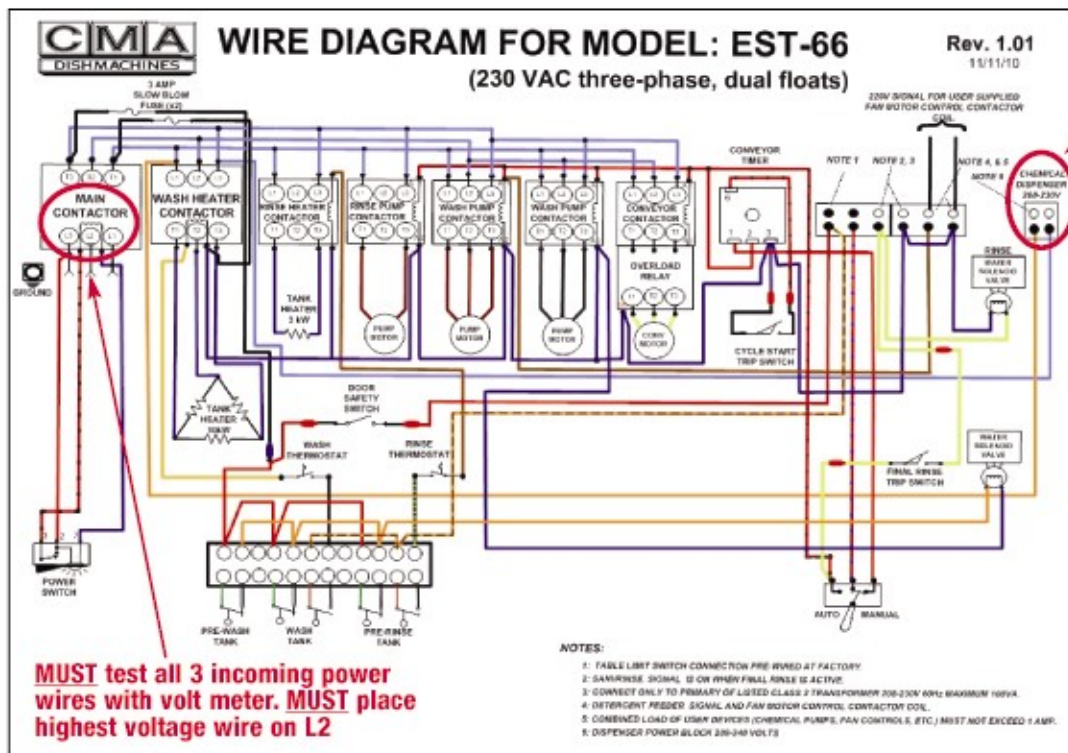

**MUST test all 3 incoming power wires with volt meter. MUST place highest voltage wire on L2**



12700 KNOTT STREET  
 GARDEN GROVE, CALIF. 92841  
 800-854-6417 • 714-898-8781  
 FAX 714-895-2141  
 www.cmadishmachines.com