



CMA PRODUCT IMPROVEMENT

Effective Date: SEPTEMBER 1, 2014
Log Number: CMA-PI-454
Subject: CMA START - RINSE ACTIVATION SYSTEM AND DOOR SAFETY SWITCH
Models Affected: EST 44 AND 66 CONVEYORS

CMA Conveyor Start-Rinse System

In being proactive, CMA has engineered an innovative way of activating the Conveyor and Rinse System on the EST Conveyors. The Reed Switch Activation System will be replaced with an electro-mechanical Switch and Rod System, which requires no adjustments and is not affected by sensitive adjustment parameters, commonly associated with reed switch and magnet assemblies. The new system incorporates a paddle that is tripped by the dishrack that turns a rod, pushing the Mechanical Push Button Switch.

CMA Conveyor Start-Rinse System Field Kit

CMA has a Field Kit available for retrofitting older model dishmachines.

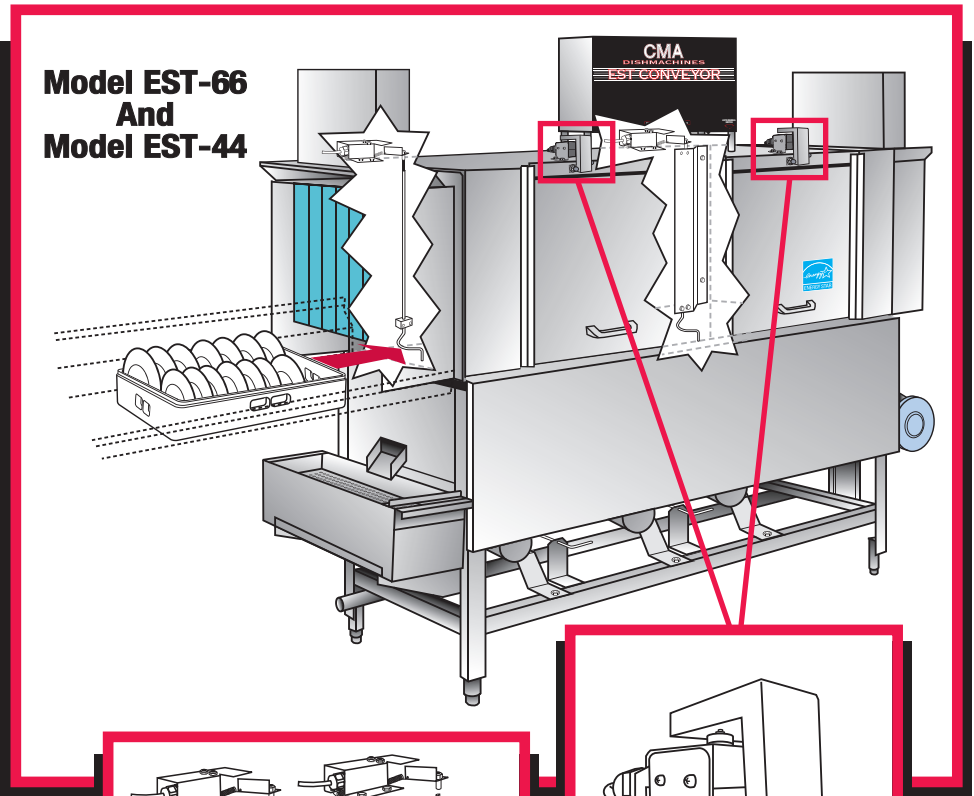

**Model EST-66
And
Model EST-44**

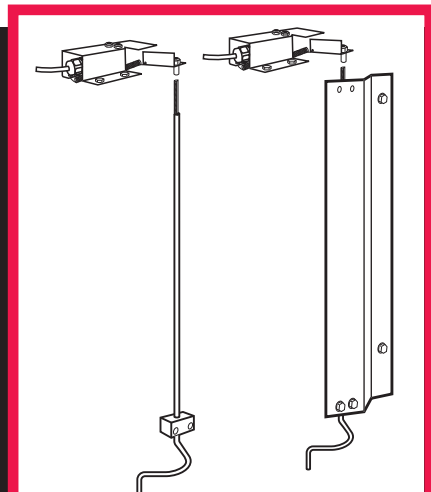

CMA Conveyor Start-Rinse System Field Kit
PN: 13978.00 (R-L)
PN: 13979.00 (L-R)

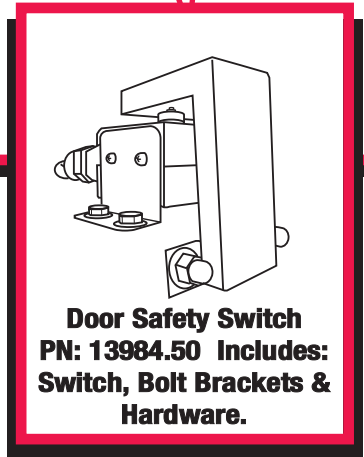

Door Safety Switch
PN: 13984.50 Includes:
Switch, Bolt Brackets & Hardware.



12700 KNOTT STREET
 GARDEN GROVE, CALIF. 92841
 800-854-6417 • 714-898-8781
 FAX 714-895-2141
 www.cmadishmachines.com